

Building instruction
A swing for small children



BOSCH

Description

Anyone with a bit of talent can build this beautiful swing for very young children. The low material costs make it a good project for beginners who want to gain experience in working with wood. If anything goes wrong, it will not cost you much. The machines needed for this project also exist in almost every home. So if you have a drill and a piercing saw and wish to invest a few hours' time, you might want to try your hand. The future owner of this toy will certainly enjoy it. And that is naturally an excellent reason to spend some time in your hobby room.

First, you should copy all the parts shown in our diagram onto the wood and cut them out with a piercing saw. The horse's head and seat are made of 18 mm pine plywood, while an 18 mm panel must be glued to another 28 mm panel for the side and rear supports.

Once the glue has hardened, the contours copied from the diagram are cut out using the piercing saw. Set the stroke length to maximum due to the 46 mm thickness of the wood, to prevent the piercing saw from becoming inaccurate. If you have a belt grinder, you can smoothen the edges you have cut. Alternately, a rasp and file are also sufficient to form the panels.

The size of the swing rope holes depends on the thickness of the rope. They are drilled around 2 cm from the end of the ledge. You can drill very even and perpendicular holes with a drill clamp. Without one, you should check the angle of your drill with a triangle when doing the job "freehanded". A drill clamp is also very useful for the notch in the seating board, in which the lower part of the horse's head will be mounted later on. Several holes are drilled next to each other so that only a small amount needs to be finished with a chisel. When working with a chisel, never go further than the middle of the board and then continue from the other side. You can create an entire notch with a chisel in this way.

Once the head fits perfectly onto the seat, all wooden edges are carefully smoothened and sanded. If you have a router and a tooth chamfering machine with ball bearings, it will guide you along the edge, regardless whether it is straight or curved. It is almost impossible to cut away too much.

If you want the horse's head to look as three-dimensional as possible, the eyes, mouth and nostrils must be carved out with a carving knife. The job can also be done either with a router and type cutter or with the new electric scraper from Bosch. It serves as an electric carving tool when used with the corresponding carving knives. Naturally, you can paint the horse's head, but be sure to use paint that is suitable for toys. The

head is then joined to seat. This requires two little wooden blocks fastened by two screws respectively under the seat. Drill two holes for the swing rope into a round 20 mm beechwood bar, which will act as a support bar (Diagram 4). Stick the support bar loosely through the head board and use 6 mm pegs and wood adhesive to fix it from the edge.

Before threading each wooden part on the rope in the right order, treat the surfaces with a brown colored wax. Two coats are sufficient, but sand the first coat before applying the second. Once they are dry, the parts are ready for assembly. Make sure that all wooden parts are in the right order, especially the 30 mm beechwood balls used as separators. Ready-to-use balls can be bought in DIY stores, where you will

also find the right swing hook and a metal sling through which to thread the rope. The rope is in one piece and threaded from under the seat upwards at the rear. It is only fastened at the front left and right ends beneath the side railing. Depending on the type of rope, grips can be used for extra hold. When you buy the rope, make sure it is really sturdy enough. Use so-called cable eye stiffeners to prevent the rope from being worn on the suspension.



1. An 18 mm plywood panel stuck to a 28 mm panel provides exactly the right wood thickness of around 46 mm. Apply the adhesive on the entire surface of only one side and fix the panels with clamps.



2. The rail ledges are cut from the glued wood panels using a piercing saw. The maximum stroke length should be used to ensure ideal right-angled cutting.



3. The curved rail ledges can best be smoothed using a belt grinder. Using the angle stop ensures that all ledges are immediately cut at right angles.



4. The holes for the swing rope are drilled around 2 cm from the end with the help of a drill clamp. A machine vice is recommended for the drill clamp when working on round bars.



5. Notches in the wood surface are first prepared by drilling several holes. A sharp chisel is then only needed for finishing the rest



6. A router and a mill cutter with a radius of 6 mm are used to break all the wooden edges. Sand the edges well first, since every uneven patch is transferred to the wood by the ball bearings.



7. To ensure that the head does not slip out of the seat, fix it with two wooden blocks. Place the screws a little apart so they do not impede each other.



8. The horse's head is especially attractive with a carved face. It is easy to form with the electric scraper and a V-shaped chisel. Try it out on a piece of scrap wood first all the same.



9. The 20 mm round beechwood bar is fixed using a 6 mm peg. A hole is drilled through the edge of the head and the bar. Cut off the peg with a fine saw if it sticks out of the wood.

Materials list

Pos.	No.	Description	Measurements in mm	Material
1	5	Head piece	305 x 260*	Pine plywood
2	1	Seat panel	405 x 250*	18 mm thick
3	2	Fixing blocks	70 x 18	
4	2	Rail ledges	330 x 53*	18 + 28 mm wood cut to shape
5	2	Support bar	220 x 40*	Pine plywood Ø 46 mm
6	1	Support bar	320 lang	Beechwood Ø 20 mm
7	4	Wooden balls	Ø 30 mm	Beechwood
Accessories: Swing rope with a swing ring and hook, Hemp rope, 6 mm diameter Peg pole, 6 mm diameter Plywood screws, Wood adhesive				

Disclaimer

Bosch assumes no liability for damage to health or property.

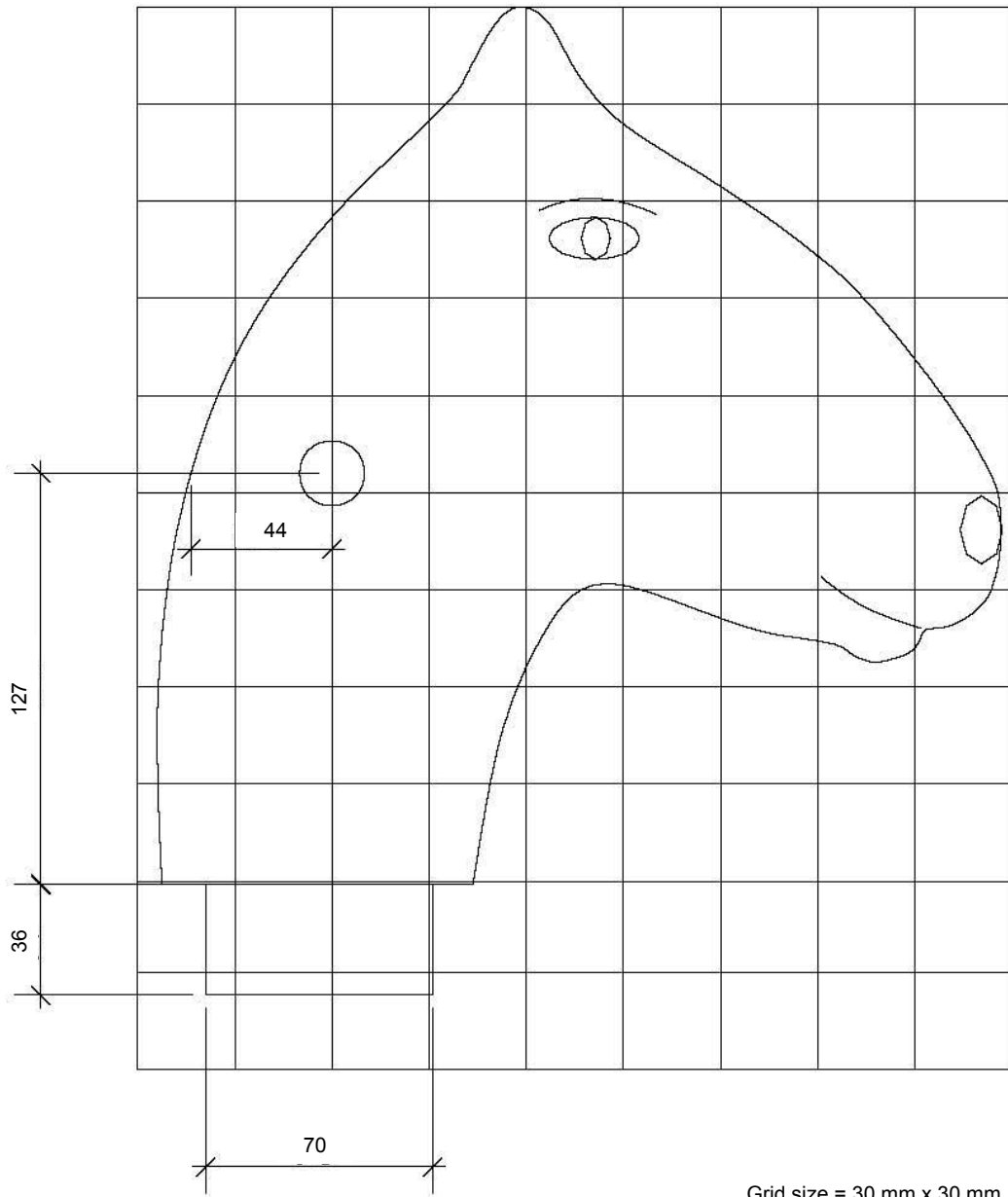

Grid size = 30 mm x 30 mm

